



L-Band to Optical Fibre Transmit Module

850-2450MHz
L-Band input converted to Optic 1310nm

Settings
Controlled by a 5 position switch with indicator lights for power & status

Compact
EMC sealed standalone housing with RF monitoring port

Flexible Mounting
Tapped screw & through hole mounting options



- Single mode optical transmitter for RF over Fibre (RoF)
- For links up to 10km
- Has monitor port
- Can provide LNB powering 13/18V, 22KHz at up to 500mA total current

Designed to work with ETL's transmit module:
SRY-RX-L1-402

Available with Optical Connectors:

- FC/APC
- SC/APC
- or RF Connectors:
- 50 Ω SMA
- 50 Ω BNC
- 75 Ω F-type
- 75 Ω BNC

RF Parameters		
Frequency Range	850 to 2450 MHz	
Flatness	±1.2dB 850 to 2150 MHz ±1.7dB 850 to 2450 MHz ±0.25dB, any 36MHz i/p > -50dBm ±0.5 dB, any 36MHz i/p < -50dBm	Full TX & RX link with 10Km fibre link using SRY-RX-L1-402. Fixed gain mode
Return Loss	50 ohm SMA 18 dB typ., 12dB min 50 ohm BNC 18 dB typ., 12dB min 75 ohm BNC 12 dB typ., 10dB min 75 ohm F-type 12 dB typ., 10dB min	All RF connectors are female. All RF ports are DC blocked
Monitor port	-20dB ±3dB	Mounted on module
OIP3	Typical 17 dBm Worst Case 14 dBm	Test condition: SRY-RX-L1-402, 0 dB optical link loss, -22 dBm tones at 2150 and 2152 MHz
CNR (in any 36MHz)	Typical -50 dB Worst Case -45 dB	Test condition: SRY-RX-L1-402, 0 dB optical link loss, -10 dBm RF i/p power, -10 dBm RF o/p total power.
NF	Typical 12 dB Worst Case 15 dB	Test condition: SRY-RX-L1-402, 0 dB optical link loss, -50 dBm RF i/p power, -10 dBm o/p power
Group Delay variation	2ns over full band 1ns over any 36MHz.	
SFDR	105 dB/Hz ^{2/3} typ., 100 dB/Hz ^{2/3} min	Test condition: SRY-RX-L1-402, 10 km fibre, -13 dBm tones at 2150 and 2152 MHz
IMD3	-65 dBc typ., -60 dBc min.	Test condition: SRY-RX-L1-402, 10 km fibre, -13 dBm tones at 2150 and 2152 MHz
RF Input Signal Range	-60 to -10dBm (total power)	Operational i/p range
Max RF input	16dBm total power	Damage level, NOT operational.

Broadcast



Marine Oil & Gas



SNG & VSAT



Satellite Teleport





Technical specifications and operating parameters

Optical Parameters		
Laser Type	DFB	Optical isolator for improved performance
Optical Wavelength	1310 ± 10 nm	
Optical Power output	4.5 ±2.5 dBm	
Optical Connectors	FC/APC SC/APC	Single mode fibre Use angle polish connectors only
Non RF Parameters		
Module swap	Hot swap	
Power supply voltage	12V ±1V	Single or dual redundant power
Power consumption	15W typical	With 18V 500 mA LNB power
LNB power	18/13V ±5 %, 500 mA max	Short circuit current 750 mA max.
MTBF	>200,000 hours	Module MTBF

Environmental conditions		
Operating Temperature	-20°C to +65°C	Mount away from sources of heat. Forced air cooling may be required dependant on application.
Storage Temperature	-40°C to +90°C	
Location	Indoor use	Outdoor use as part of ETL ODU only
Humidity	20 to 90% non-condensing	Relative Humidity
Altitude	10,000 ft AMSL operational 30,000 ft AMSL storage/transport	Above mean sea level
Mass	0.35 Kg typical	

Control, Monitoring & Alarms			
Control	1	LNB on/off	Remove cover to access DIP switch
DIP Switch	2	LNB 13/18V	
Position	3	LNB 22 KHz on/off	
	4	AGC on/Gain fixed	
	5	Reserved	
Indicator lights		Module powered Module OK Internal monitoring alarm	
Monitoring includes		Laser Optical Output Power Status of amplifier stages Module temperature	Monitored in each module
AGC		Factory set	Once AGC level set, gain can be fixed

! Operation beyond these limits may cause instantaneous and permanent damage.

Physical Dimensions (mm)

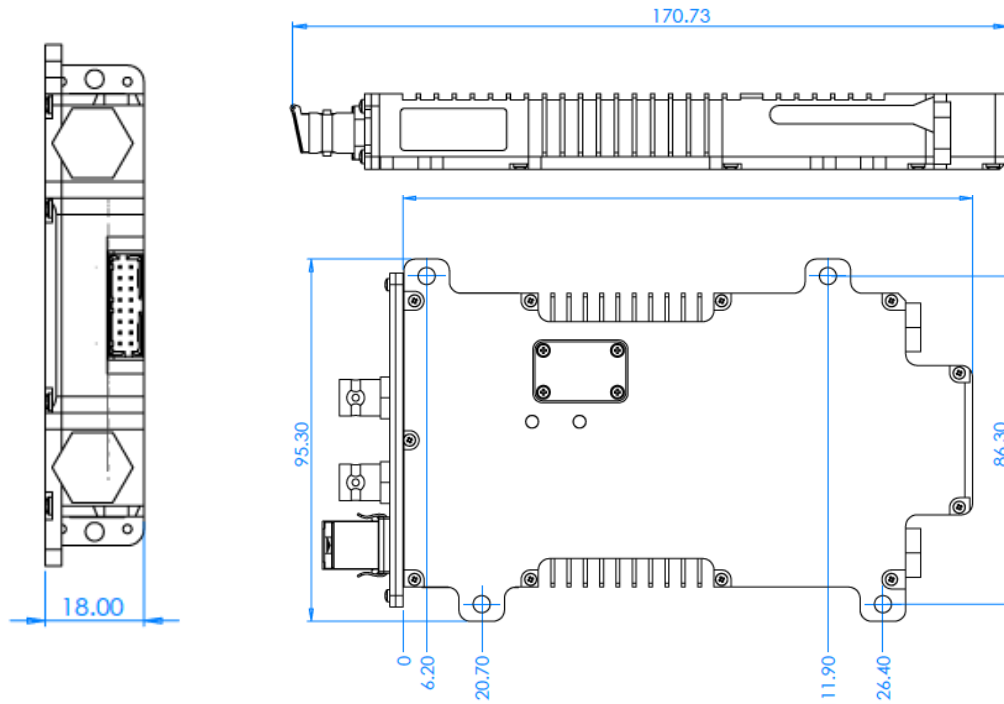

Note 1: The specification is subject to regular reviews and will be updated from time to time as part of our continuing product development and improved specification accuracy.

